



AFWERX

AFVENTURES

Open Topic Overview & AMA
AFX246-DPCS01 & DPCS02
(SBIR D2P2)

25 April 2024

Rules of Engagement

1. Call is recorded and will be available on AFWERX.com
2. No classified/proprietary Information
3. Post questions in the Q&A section (not via chat)

All information is subject to change. The final, authoritative source of info & requirements is the solicitation instructions found on DSIP.

Branch Org Inboxes

- Open Topic Phase I: p1@afwerx.af.mil
- Open Topic Phase II: p2@afwerx.af.mil
- Specific Topic: usaf.team@afsbirsttr.us
- STRATFI/TACFI: stratfi.tacfi@afwerx.af.mil



Visit our website at [AFWERX.com](https://afwerx.com)
and social media channels:



Department of the Air Force (DAF) Open Topic Solicitation

Topics are truly “open” and agnostic of industry, technology, or problem area.

We are seeking...

- Innovative, dual-use tech solutions (i.e. applicable to defense and non-defense)
- Clear potential to solve a DAF mission need (USAF, USSF)
- Capability to prototype under an accelerated schedule
- Ability to scale and grow the industrial base for defense
- Commitment from an empowered DAF end-user and customer
- Applied R/R&D efforts rather than “front-end” or basic research

Open Topic Annual Cycle

Phase I solicitations include SBIR and STTR / D2P2 solicitations include SBIR only

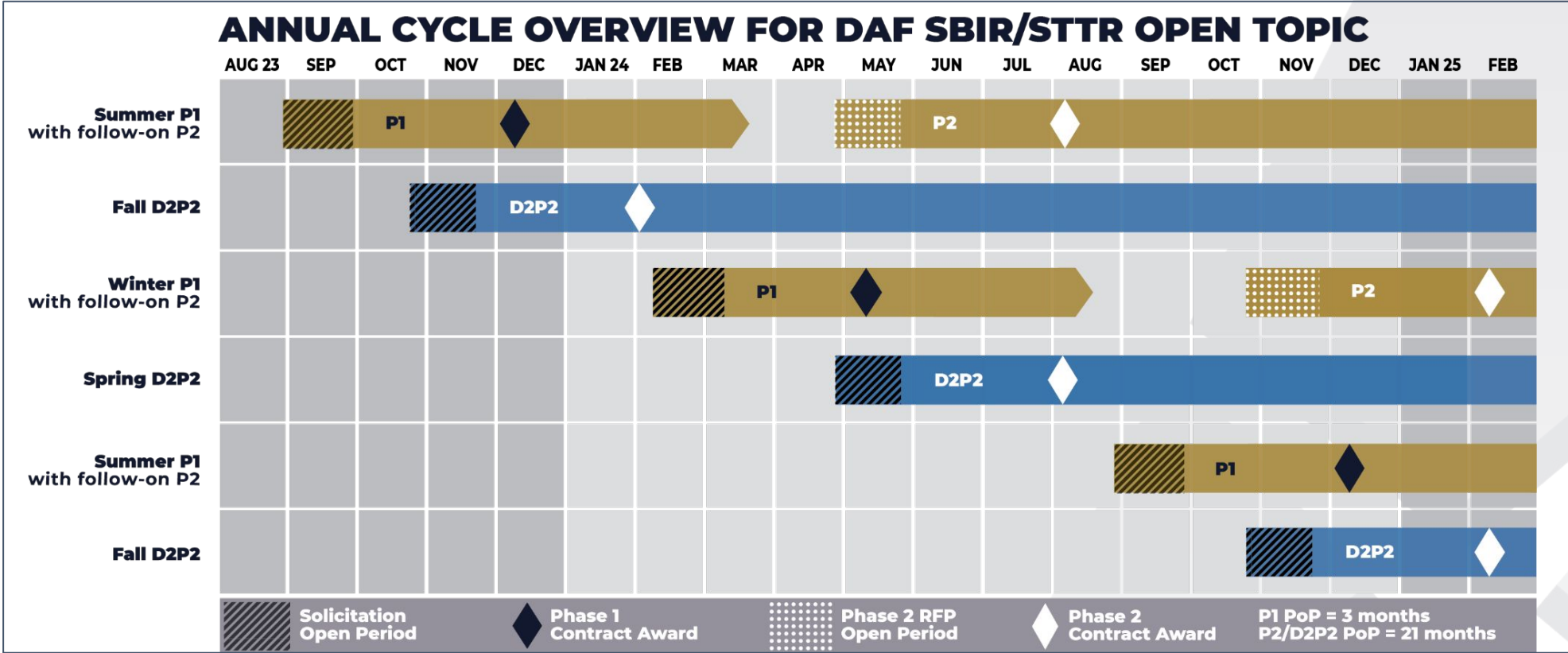

<p>Phase I Feasibility Study</p>	<ul style="list-style-type: none"> • SBIR up to \$75K per award • STTR up to \$110K per award • Three month period of performance • ~700 awards per year 	<p>Phase II Prototype</p>	<ul style="list-style-type: none"> • SBIR up to \$1.25M per award • STTR up to \$1.8M per award • 21 month period of performance • ~350 awards per year
---	--	--------------------------------------	---

Solicitations vs. Topics*

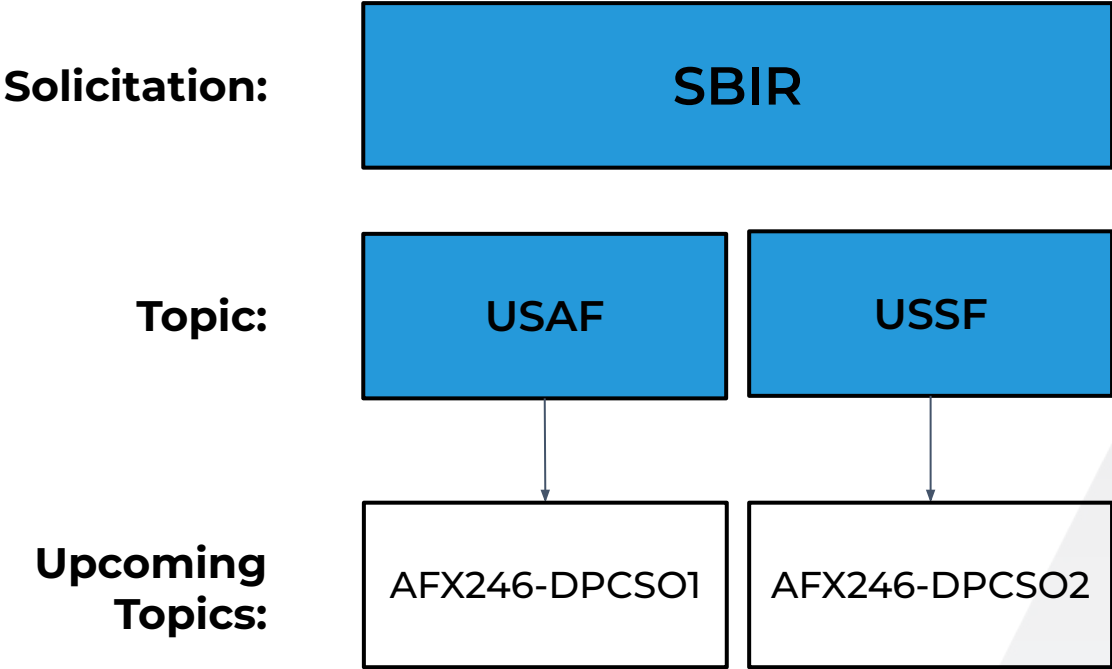

*Only applies to Open Topic. Specific Topic uses a different framework.

Evaluation Rules

Solicitation:

SBIR

Topic:

USAF

USSF

Upcoming Topics:

AFX246-DPCSO1

AFX246-DPCSO2

A business may only submit one proposal per solicitation.

A business is prohibited from submitting a proposal under both topics within a single solicitation.

Open Topic Spring D2P2

AFX246-DPCSO1 (USAF) & DPCSO2 (USSF)

24 April 2024: DAF begins accepting proposals

23 May 2024: Full proposals due no later than 12:00 p.m. ET

Period of Performance: 21 months

Max Award: \$1.25M

Customer memorandum is required

All proposals must be prepared and submitted through the Department of Defense (DOD) SBIR/STTR Innovation Portal (DSIP)

<https://www.dodsbirsttr.mil/>

Phase I-Like Feasibility Study

- Direct to Phase II (D2P2) awards are granted to continue the research and development (R&D) from prior non-SBIR research and feasibility studies, aka 'Phase I-like effort'.
- Proposals should demonstrate sufficient technical progress or problem-solving results to warrant more extensive Research Development Test and Evaluation (RDT&E) via a comprehensive, detailed description of previous efforts.
- **Feasibility documentation cannot be based upon or logically extend from any prior or ongoing federally funded SBIR or STTR work.**

What is Research or Research & Development (R/RD)?

1. A **systematic study** directed toward **greater knowledge or understanding of the subject studied**
2. A **systematic study** directed specifically toward **applying knowledge and innovation to meet a recognized but unmet need**
3. A **systematic application of knowledge and innovation** toward the production of useful materials, devices, and systems or methods, **including design, development, and improvement of prototypes and new processes** to meet specific requirements
Includes **ALL** fields (physical sciences, engineering, ect)

Why Does R/R&D Matter to SBIR/STTR Applicants?

SBIR/STTR programs are funded by RDT&E appropriations. Use of these funds is governed by federal financial law. Therefore, proposed projects must meet certain definitions and requirements to be eligible for SBIR/STTR funding.



R/R&D concerning COTS & NDIs

Items purchased directly from a commercial source that can be utilized without alteration through design and development, or without modification, are commercial off-the-shelf (COTS) or nondevelopmental items (NDI). This includes ready-to-use software, training services, and ready-to-use products.

COTS and NDIs by themselves are not suitable for SBIR/STTR funding.

****HOWEVER****

There **may** be exceptions if:

- The end item requires design and development in order to accept the COTS/NDI
- The COTS/NDI are required for RDT&E test purposes
- The proposal involves significant modification of COTS/NDI
 - To satisfy user requirements
 - Develop a capability

R/R&D Suggestions

- Demonstrate completion of R/R&D through means not solely based on previous efforts under the SBIR/STTR Programs to establish Phase II proposal feasibility based on criteria provided in the D2P2 topic descriptions
- **Feasibility documentation cannot be based upon or logically extend from any prior or ongoing federally funded SBIR or STTR work.**
- Ensure your proposal is explicit in explaining the RDT&E work you will be accomplishing
- Ensure your proposal does not lump R&D costs under licensing to provide clarity to the actual costs

SBIR/STTR Phase II & D2P2 Proposal Structure

- **Vol 1: Proposal Cover Sheet (SAM, UEI, CAGE, Abstract, etc)**
- **Vol 2: Technical Volume**
 - Mandatory white paper
 - 15 page maximum, excluding table of contents and glossary (pages in excess NOT reviewed)
- **Vol 3: Cost Volume**
 - System formatted inputs
- **Vol 4: Company Commercialization Report (CCR)**
 - Follow solicitation instructions for Volume 4
 - CCR information is maintained and report is generated via sbir.gov
 - CCR is uploaded to DSIP as part of the proposal submission process, as applicable

SBIR/STTR Phase II & D2P2 Proposal Structure, Cont'd

- Vol 5: Supporting Documents

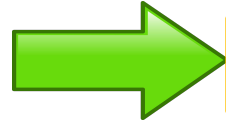

MANDATORY customer memorandum (CM) on required template**

- **Attachment 8:** Disclosures of Foreign Affiliations or Relationship to Foreign Countries
- **Attachment 12:** Regulatory Compliance Information for Phase II
- *IP agreement with RI (SBA template available) (STTR ONLY)
- Additional required attachments (Ie: DoD funding agreement certification, work plan (non-proprietary), lifecycle certification, ESOH questionnaire)

- Vol 6: Fraud, Waste, and Abuse Training

IMPORTANT:
Proposals that do not include properly prepared Attachments 8 and 12 will also be deemed noncompliant and will not receive an evaluation.

Customer Memorandum

Signatures



- 3 CAC-enabled, digital signatures required (Customer, End-User, & TPOC) on a single memorandum
- Must be government (either Military or Civilian)
- FFRDC/Support contractors **MAY NOT SIGN**
- Customer or end-user may be non-DAF member from a DoD joint org
- TPOC **MUST** be a DAF (USAF or USSF) member in all cases

Customer/End-user may be from same organization, but **must not** be the same person.

Your proposal is limited to **ONE** completed memorandum

<p>20 Customer (FIRST MI LAST, RANK/GRADE, USAF)</p> <p>John Smith, GS-14, USAF</p> <p>↓ NOTE: A CAC-enabled, digital signature is required here AND in the field to the right.</p> <p>Smith.John n.111111</p> <p>Digitally signed by John.Smith.111111 Date: 2023.08.08 12:18:25 -04'00'</p>	<p>21 End-User (FIRST MI LAST, RANK/GRADE, USAF)</p> <p>Jane Doe, Maj, USAF</p> <p>↓ NOTE: A CAC-enabled, digital signature is required here AND in the field to the left.</p> <p>Doe.Jane .222222</p> <p>Digitally signed by Jane.Doe.222222 Date: 2023.08.10 14:27:13 -04'00'</p>
<p>22 Primary TPOC Signature (FIRST MI LAST, RANK/GRADE, USAF)</p> <p>Good, Michael, SSgt, USAF</p> <p>↓ NOTE: A CAC-enabled, digital signature is required here.</p> <p>Good.Michael.333333</p> <p>Digitally signed by Michael.Good.444444 Date: 2023.08.12 08:55:19 -04'00'</p> <p>By signing this memorandum, you acknowledge you understand, accept, and will abide by the full terms and conditions outlined in the TPOC Designation Section.</p> <p>NOTE: If you are actively planning to change jobs, PCS, or retire within the next 6 months, please advise your TPOC to support this effort.</p>	

Must be a DAF member in all cases.

Customer Memorandum

IMPORTANT INFORMATION



Your proposal is limited to a single customer memorandum with three digital, CAC-enabled signatures

- Multiple memorandums with individual signatures are NOT accepted and will result in disqualification
- Scans, photos, and image reproductions of the form are NOT accepted as they do not allow for digital signature verification
- Avoid using Adobe Distiller to complete or modify the form - we suggest using Adobe Acrobat to mitigate data corruption issues

Failure to comply with these requirements may be grounds for disqualification.

Additional Funds (non-SBIR)

- Phase II awards are intended to provide a commercialization path, and are not proposed solutions' final step.
- Phase II commitments from non-SBIR federal and non-federal sources are not mandatory. Cost-share is also not required. However, second phase commitments may serve as commercial potential evidence in accordance with 15 USC 638(e)(4)(B)(ii).
- If applicant proposes matching non-SBIR government funding or matching private funding, a Phase II funding commitment form (Attachment 11) is required.
- For government Phase II commitments:
 - If the funds are to be applied directly to the D2P2 contract, the draft funding document (e.g. MIPR or Form 9) must be received by AFRL/RGF within *45 days* of CSO closing
 - To start the process, the government organization must email AFRL.SBIR.STTR@us.af.mil.

Additional Funds (non-SBIR)

- For private investment:
 - A letter as detailed in Attachment 11 (Phase II Funding Commitment Form) must be submitted with the proposal
 - Additionally, the awardee must provide evidence of funds receipt within 90 days of award and provide it to the Government Agreements Officer
- Price reasonableness and realism will be considered to the extent appropriate. IAW 15 USC 638(dd)(7), investment by venture capital, private equity firms, or hedge funds shall not be used as an award criterion.
- Second phase funding commitments may serve as evidence of commercial potential IAW 15 USC 638(e)(4)(B)(ii).

Submission Requirements

- All eligible offerors must be qualifying, registered small businesses in SAM.gov prior to award, we suggest registering early to avoid delays!
- This solicitation is for **Direct-to-Phase II only**
 - Max contract terms of \$1.25M, 21 months period of performance
- Complete proposals must be submitted via the Defense SBIR/STTR Innovation Portal (DSIP)
 - Proposals cannot be pre-read or recommended for submission
 - No email or other non-DSIP submissions will be received
- Must be RDT&E activities
 - Not services or procurement
 - See modified-COTS description in solicitation: Section 3(b)(v)
- Fraud, Waste, and Abuse training - Volume 6
 - Must be completed by one DSIP firm user with read/write access (proposal owner, corporate official, or firm admin) on behalf of the firm
- **Proposals that do not meet submission requirements will not be accepted**

Common Causes for Non-Selection

- Exceeding Cost or Duration Limits - \$1.25M and 21 months max
- SAM.gov Registration - firms must have an active registration prior to award, we suggest registering early to avoid delays!
- Missing Documentation - all required volumes and attachments must be included
 - Invalid or missing Customer Memo
 - Must have THREE valid signatures
 - Must use the most recent version with the matching solicitation header
 - Unsigned or missing Attachment 8: Disclosures of Foreign Affiliations or Relationships to Foreign Countries
 - Missing or incomplete Attachment 12: Regulatory Compliance Information for Phase II
- Multiple Submissions
 - A small business concern may only submit **one** proposal under each solicitation
 - A small business concern is prohibited from submitting a proposal under both topics (i.e., submit to both the AF and SF topics of a single D2P2 SBIR solicitation)
 - If more than one proposal from a small business concern is received for a single solicitation, **only the most recent proposal to be certified and submitted prior to the submission deadline** will be eligible for evaluation

Common Proposal Issues

- Not addressing solicitation requirements, particularly evaluation criteria (see solicitation: Section 4, Method of Selection and Evaluation Criteria)
- Unclear proposed benefit to the government customer (see solicitation: Table 5: Technical Volume Content Description)
- Inconsistent milestones/timelines and proposal not matching customer memorandum (see solicitation: Table 6: Non-Proprietary Phase II Work Plan Outline)
- COTS/Software licenses appropriateness for proposed effort (see solicitation: Section 3(b)(v))

What's Next?

- **Proposals due Thursday, 23 May 2024 @ Noon ET**
 - Do not wait until the end of the submission period to submit proposal materials
 - All proposals must be submitted via DSIP (<https://www.dodsbirsttr.mil/>)
- **Be familiar with Evaluation Criteria**
 - Commercialization potential
 - Defense need
 - Technical merit
- **Questions must be answered publicly via DSIP Q&A or AMA webinars**
 - The solicitation is the final, authoritative source of info & requirements
 - Questions answered via email will be limited to non-substantive, administrative questions only, e.g. proposal formatting, proposal submission instructions, etc.

Solicitation Resources

Contracting Officer: Mr. Daniel Brewer

Program Manager: Emily Primeaux

For technical questions, use DSIP Q&A section

<https://www.dodsbirsttr.mil/submissions/baa-schedule/active-baa-announcements>

For proposal preparation questions, email usaf.team@sbirsttr.us

Customer memorandum 23.7/E Phase II and 24.6 D2P2 required Form

[23.7E-24.6-D2P2-Customer-Memorandum-AFRL-2024-1083.pdf \(afwerx.com\)](https://afwerx.com/23.7E-24.6-D2P2-Customer-Memorandum-AFRL-2024-1083.pdf)

IMPORTANT: One memo with three digital signatures is required. Three memos with one signature each will not be accepted. Scans, photos, and image reproductions of the memo also not accepted.

28 Mar 24 Completing the Customer Memorandum: Open Topic Phase II and D2P2

[Webinar Recording](#)

[Webinar Presentation Slides](#)

Additional Resources

SBIR.gov Tutorials

<https://www.sbir.gov/tutorials/>

Defense SBIR/STTR Innovation Portal (DSIP) Tutorials

<https://www.dodsbirsttr.mil/submissions/learning-support/training-materials>

Defense SBIR/STTR Innovation Portal (DSIP) Home Page

<https://www.dodsbirsttr.mil>

AFWERX.com:

<https://afwerx.com/>

AFVentures Weekly Webinar Series

<https://afwerx.com/afventures-weekly-webinar-series/>

Open Topic Phase II Team

p2@afwerx.af.mil



AFWERX
AFVENTURES



Questions?

Please type your questions in the Q&A section.

Let us know how we are doing. Please complete the survey as you leave today's meeting.